

Directional Control Valves for Hazardous and Corrosive Environments.

OPERATING INSTALLATION AND MAINTENANCE INSTRUCTIONS

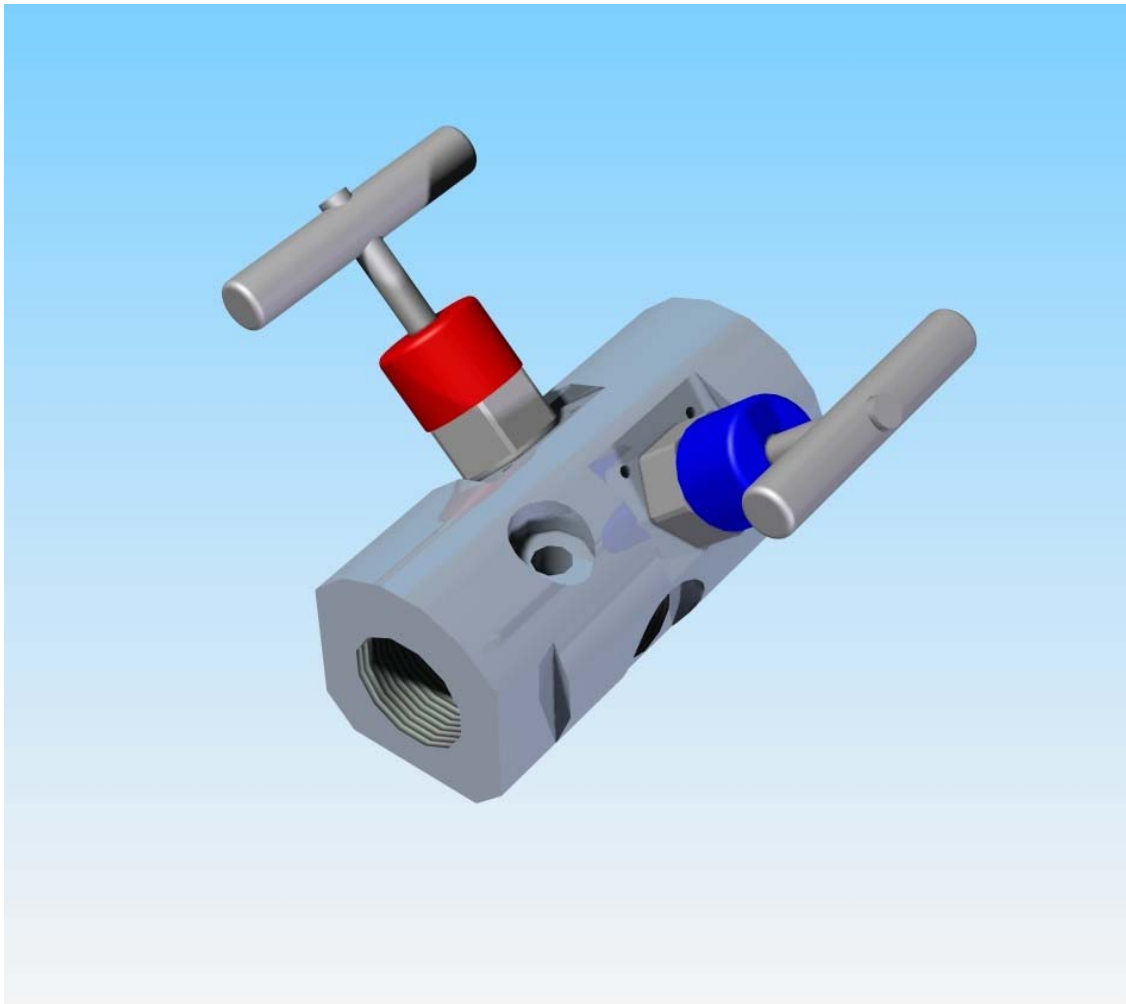

Two Valve Block & Bleed Gauge Manifold

Valve Range NV04

INDEX

SECTION 1.0	GENERAL
SECTION 2.0	INSTALLATION / REMOVAL
SECTION 3.0	OPERATION
SECTION 4.0	MAINTENANCE

1.0 GENERAL

This procedure applies to single block and bleed gauge manifolds with 2 screwed type needle valve head units, rated for pressures as stated on the valve, and purchase order. The manifold layout is as shown in the figure on page 4, consisting of:

The process inlet connection either threaded or welded.

Vent connection, threaded.

Instrument gauge / outlet connection, threaded.

Isolation needle valve and Vent needle valve.

2.0 INSTALLATION / REMOVAL

When installing this product suitable thread sealant should be used in conjunction with the tube fittings. Thread tape or similar should not be used.

When making up threaded connections, ensure the correct sized spanner is used on the flats provided on the valve. Do not use the needle valve head units as a lever to tighten the valve connections.

Valves with welded connections are designed with extended ends to reduce the effects of heat transfer during installation; it is recommended however that wherever possible, additional precautions be taken to avoid damage to the valve seals during welding.

Note: Removal of the needle valve head units during installation will void the valve warranty and invalidate any factory testing certification supplied with the valve.

It is recommended that all tubing is thoroughly cleaned prior to the valve being installed.

Precautions must be taken to avoid the ingress of dirt when a valve is removed from a system.

3.0 OPERATION

Valves are supplied tested at 1.5 times the maximum working pressure stated on the valve. Do not exceed the maximum working pressure under normal operating conditions.

During normal operation the isolation valve should be in the open position (approximately 7 turns to fully back-seat) and the vent securely closed.

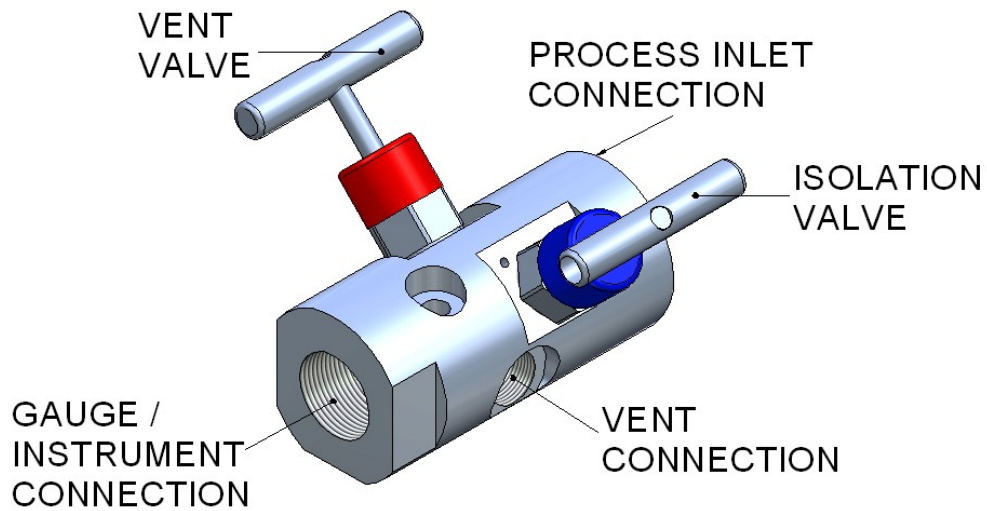

To isolate the gauge / instrument to allow for removal or other maintenance, close the isolation valve, ensure the vent port is either connected to tank via a suitable tube or if the vent is plugged the plug removed, open the vent valve. This will isolate the gauge / instrument from the process fluid, and vent the pressure from the gauge / instrument. The gauge / instrument can now be removed from the valve manifold.

Under no circumstances should the isolate valve be opened whilst the gauge / instrument is removed from the valve manifold.

After the gauge/instrument has been removed and re-fitted (replace the vent plug if required), securely close the vent valve then open the isolation valve.

4.0 MAINTENANCE

4.1 ANNUAL No annual maintenance is required.